

## SERIES 61Z

High Resolution, Redundant  
Circuitry, 7-Pin

### FEATURES

- 25, 32, 50, 64, 100, 128 and 256 Cycles per Revolution
- Rugged Construction
- 10 Million Life Cycles
- 300 RPM Shaft Rotation
- Shaft and Panel Seals Available
- Custom Cable Versions



### DIMENSIONS In inches (and millimeters)

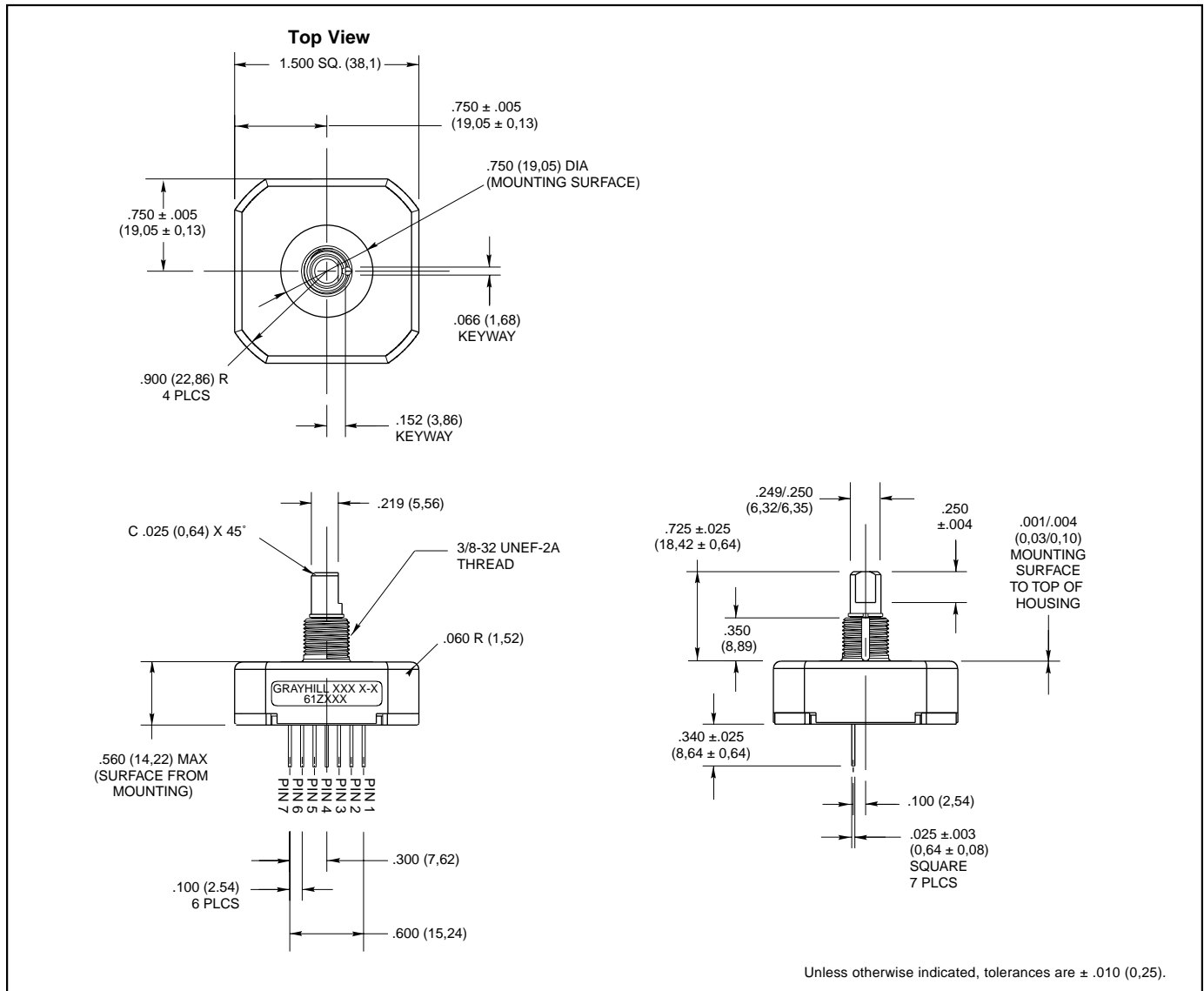

## CIRCUITRY AND WAVEFORM: Standard Redundant Quadrature 2-Bit Code

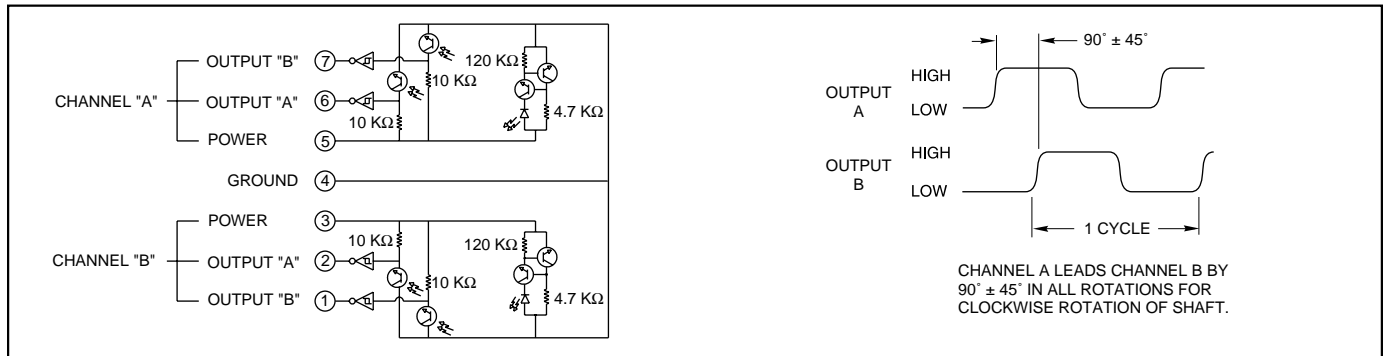

## SPECIFICATIONS

### Electrical Ratings

**Operating Voltage:**  $5.0 \pm .25$  Vdc  
**Supply Current:** 50 mA maximum at 5 Vdc  
**Logic Output Characteristics:**  
 Output Type: Open collector and 10 KΩ pull-up resistor with integrated Schmitt Trigger  
 Maximum Sink Current: 16 mA at .40V  
**Power Consumption:** 250 mW maximum at 5 Vdc  
**Optical Rise Time:** 500 nS typical  
**Optical Fall Time:** 16 nS typical

### Mechanical Ratings

**Mechanical Life:** 10 million revolutions  
**Time Life:** Guaranteed for 10 years of continuous operation (calculated from emitter degradation data)  
**Mounting Torque:** 20 in-lbs maximum  
**Shaft Push Out Force:** 100 lbs  
**Terminal Strength:** 5 lbs terminal pull-out force minimum  
**Solderability:** 95% free of pin holes and voids  
**Operating Torque:** 1.5 in-oz maximum (no detents) for unsealed versions

### Environmental Ratings

**Operating Temperature Range:**  $-40^\circ\text{C}$  to  $85^\circ\text{C}$   
**Storage Temperature Range:**  $-55^\circ\text{C}$  to  $100^\circ\text{C}$   
**Relative Humidity:** 90-95% at  $40^\circ\text{C}$  for 96 hours  
**Vibration Resistance:** Harmonic motion with amplitude of 15g, within a varied 10 to 2000 Hz frequency for 12 hours per MIL-STD-202, Method 204  
**Shock Resistance:** Test 1: 100g for 6 mS, half-sine wave with velocity change of 12.3 ft/s. Test 2: 100g for 6 mS, sawtooth wave with velocity change of 9.7 ft/s.

### Materials and Finishes

**Bushing:** 6262-T9 aluminum alloy  
**Housing:** Hiloy 610B  
**Shaft:** Stainless steel insert molded into nylon rotor support  
**Code Rotor and Aperture:** Chemically etched stainless steel/electroformed nickel  
**Printed Circuit Board:** NEMA Grade FR-4. Five microinches minimum gold over 100 microinches minimum nickel over copper  
**Optical Barrier:** Polyphthalamide (PPA)  
**Backplate:** Polyester  
**Pin Header:** Phosphor bronze, 200 microinches tin over 50 microinches nickel (pin version only)  
**Infrared Emitter:** Gallium aluminum arsenide  
**Photo IC:** Planar silicon  
**Retaining Ring:** Stainless steel

## ORDERING INFORMATION

**Series**  
**Style:** Z = Standard, high resolution, redundant circuitry, 7-pin  
 ZS = Sealed, high resolution, redundant circuitry, 7-pin  
**Cycles:** per channel per revolution = 25, 32, 50, 64, 100, 128, 256

**61ZS256**

For Accessories see page E-23 for details. Control knobs available, see page E-39.

**Available from your local Grayhill Distributor. Call in CHINA (Beijing): Phone: (010)6851-9889, Fax: (010)6851-5578.**